



ROSATOM

ROSATOM STATE CORPORATION COMPANY



R3 Optioneering, Concept Design and EIAR Development

Visaginas 25.10.2018



Our team



Lithuanian partners

**Other Russian partners,
if necessary**

Our team consists of the following German and Russian companies experienced in design and implementation of nuclear decontamination & dismantling projects worldwide:

- Kurchatov Institute – Scientific Leadership in Irradiated Graphite Management
- NIKIET – Chief Designer of RBMK-type reactors
- NUKEM – International Projects Management, Reactor Dismantling
- Other Russian partners will be included if deemed necessary:
 - JSC TENEX (Russia) – Project management and overseas business
 - OJSC NIKIMT-Atomstroy (Russia) - Research and Design Institute of Installation Technology, and others
- Lithuanian partners will be included

The project requires the participation of Lithuanian partners

The Project Tasks

In accordance with the information provided for the preparation of the work shop, our team has to fulfill the following tasks:

- Task 1: Development and submittal of methodology
- Task 2: Gap analysis/ collection of information
- Task 3: Optioneering and development of conceptual design
- Task 4: Support of INPP during coordinating Task 3 outputs with VATESI (the regulatory body), CPMA and Ministry of Energy (the owner).
- Task 5: EIAR development
- Task 6: Support of INPP during EIAR approval under Law on environmental impact assessment and Espoo convention

The Team – Functions of Each Team Member



Lithuanian partners

**Other Russian partners,
if necessary**

	Experience / Function	Tasks
TENEX	Team Integrator within Rosatom	All Tasks
Kurchatov Institute	Scientific Leadership in Irradiated Graphite Management, provision of available INPP reactors commissioning and operation archive	All Tasks
NIKIET	Chief Designer of RBMK-type reactors, provision of available INPP reactors design and operation archive	All Tasks
NIKIMT	Irradiated Graphite Retrieval Technics, provision of LNPP reactors reconstruction and maintenance experience	Task 3
NUKEM	International Projects Management, Reactor Dismantling optioneering and conceptual design development, EIAR development with local partners	All Tasks
Lithuanian partners	Conceptual design and EIAR development in Lithuanian format based on the team members input, support of INPP in Tasks 3+5	All Tasks

Task 1: Development and submittal of methodology

Our team has successfully implemented similar tasks in the following decommissioning projects:

- Ignalina B9.0, Lithuania: Bldg 117/1 D&D Project Development
- Ignalina B9.2, Lithuania: D&D of building V1 of Unit 1
- Kurchatov Institute Reactor MR, Russia: D&D of research reactors to brown field conditions;
- Kurchatov Institute Reactor RFT, Russia: D&D of research reactors to brown field conditions and removal of 34 tons of graphite to interim storage facility at FSUE Radon site (by using of containers H3K-150-1,5Π – container with protective metallic liner)
- Fukushima Daiichi NPP, Japan: Fuel debris removal feasibility studies
- Fukushima Daiichi NPP, Japan: Remotely-operated field work feasibility studies
- Kozloduy NPP, Bulgaria: Elaboration of a design for dismantling of equipment in the controlled areas of Kozloduy Units 1-4
- Brennilis NPP, France: Decommissioning & dismantling planning of reactor unit (HWGCR)
- ADE-5, Russian Federation. Optioneering for ADE-5 graphite stack dismantling

Detailed information will be provided further.

Our team has relevant experience and will be able to accomplish the project within time, cost and quality constraints.

Task 2: Gap analysis/collection of information

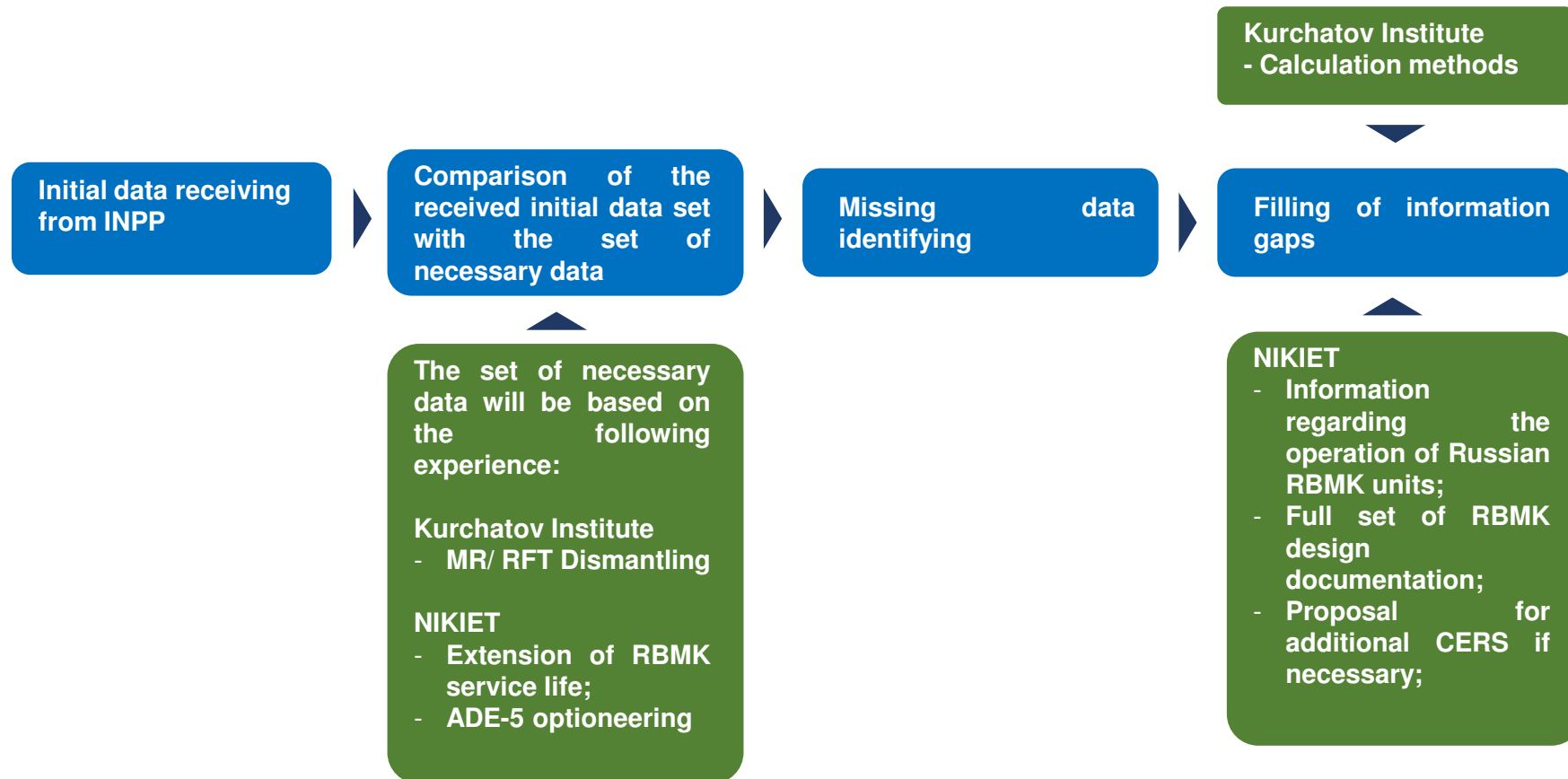

Possession of information on similar reactors as well as available calculation methods will allow us to fill the gaps in the initial data.

Task 2: Gap analysis/collection of information

At the moment we have the following initial data:

- Operation documentation from Ignalina NPP;
- CERS results from INPP*;
- Existing project and technical documentation from INPP;
- Information regarding the Russian RBMK units operation (including design documentation);
- 3D models of RBMK units;
- Space-planning and design solutions;
- Transport routes of communication;
- List of objects necessary for transport and technological operations;
- Existing acceptance criteria;
- Rules for RW collection and transfer

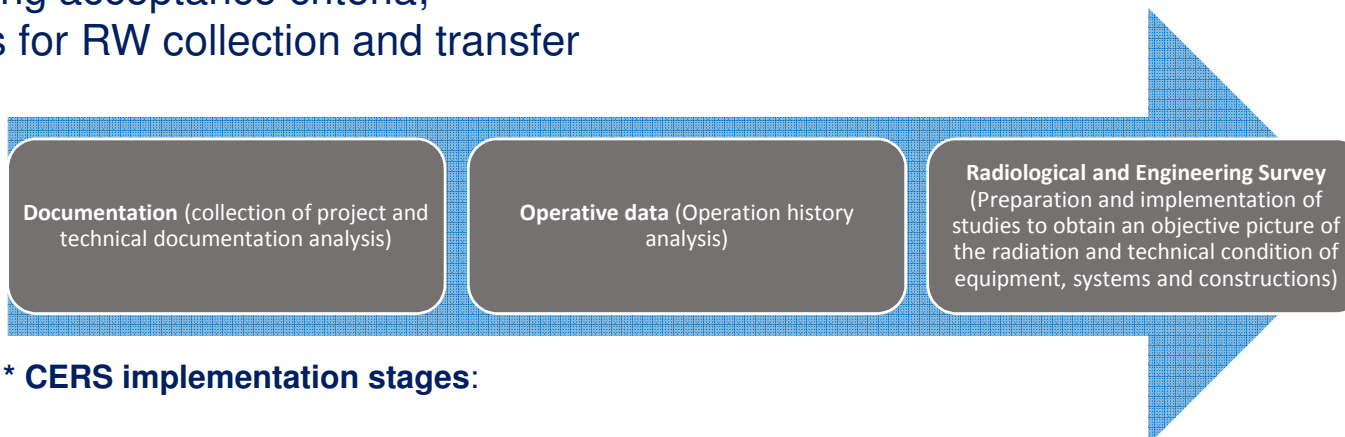
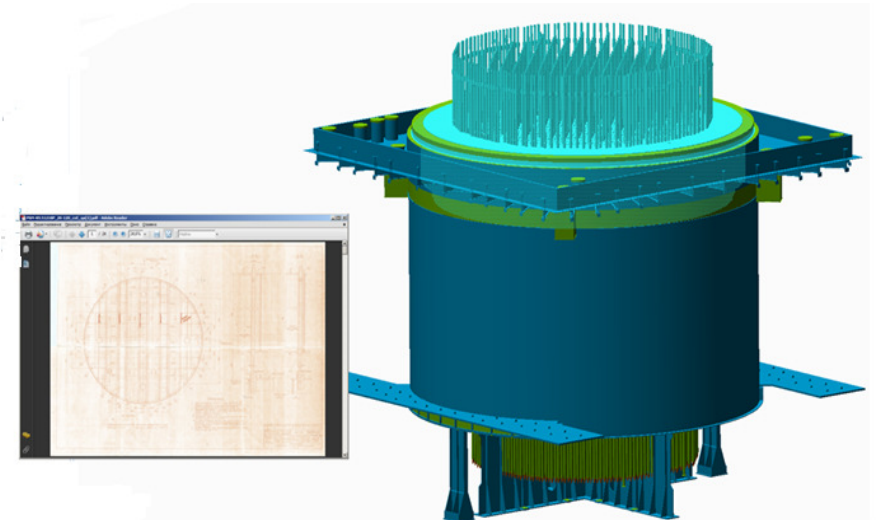

* CERS implementation stages:

Task 3: Optioneering and development of Conceptual Design

In our capacity as Consultant, our scope of Task 3 will encompass all activities necessary for the subsequent safe and cost-effective implementation of the Decontamination and Dismantling (D&D) activities by the INPP.

In order to successfully achieve this objective, the team is ready to provide to INPP:

- As a minimum two options of R3 D&D solution, taking into account:
 - ALARA principles;
 - Identified suitable D&D methods;
 - Provided or collected radiological data;
 - Information on hazardous waste;
 - INPP expectations.
- Criteria (technical / economic) for the analysis of developed options based on the team's similar reference projects;
- Conceptual Design package for the chosen D&D solution, which INPP will use as an input for Licensing and Regulatory approvals according to the Lithuanian Laws and VATESI Regulations on Decommissioning, RAW Management and Radiation Protection.
- Results of the team's observation on particular internationally recognized techniques to qualify and quantify selected attributes, e.g. IEC/ISO 31010:2009 (LST EN 31010); IAEA-TECDOC-1777; IAEA-TECDOC-1817, etc. for optioneering purposes including nuclear power facility's D&D and waste management safety.

Task 3: Optioneering and development of Conceptual Design

NUKEM Technologies Engineering Services (NUKEM)

Project 44: „Elaboration of a design for dismantling of equipment in the controlled areas of Kozloduy NPP VVER-440 Units 1-4”, Bulgaria.

Task 5: Design documentation package for the dismantling of the primary circuit and the components within Unit 1 Reactor Building, including associated SAR.

- Elaboration of a Conceptual Design for dismantling of the primary circuit and its components, incl. RPV and RI:
 - Option 1: Dismantling of the RPV and RI without segmentation inside RB;
 - Option 2: Dismantling and segmentation of the RPV and RI inside RB.
- Elaboration of a Basic Design for Employer’s preferred Option;
- Development of an input for revision of SAR.

Main Criteria for technical and economic assessments, as follows:

- i. Applicable dismantling technologies,
- ii. Decontamination requirements;
- iii. RAM and RAW management;
- iv. Availability of temporary storage areas, facilities for treatment and disposal;
- v. Requirements for disposal containers (type; quantity; availability);
- vi. Occupational safety and radiation protection;
- vii. Cost and prices for implementation work, tools, consumables, temporary storage, etc.
- viii. Project duration / schedule.

NUKEM has implemented a similar project for optioneering at Kozloduy NPP.

Task 3: Optioneering and development of Conceptual Design

NUKEM Technologies Engineering Services (NUKEM)

Fukushima Daiichi NPP Projects: Feasibility studies to investigate key aspects and challenges of planned fuel debris removal task

- Study for mapping of primary circuit floor and removal of interference material;
- Study for biological shielding wall cutting and dismantling method;
- Study for rail-bound carrier system;
- Study for of fuel debris retrieval cell transportation.

To fulfil the client's requirements, NUKEM has provided the following services:

- Use of standard evaluation methods for selection of most suitable technologies;
- Development of concept variation according to standard criteria;
- Concept design for preferred concept variation;
- Execution of safety and sensitivity assessment.

Position	Option	Description	Percentage points	Change in position
1	I	Hatch #1 + Jackhammer	78.24%	0
2	VII	Hatch #4 + Jackhammer	68.63%	+1
3	III	Hatch #2 + Jackhammer	64.82%	0
4	V	Hatch #3 + Jackhammer	61.63%	+1
5	II	Hatch #1 + Drilling	60.60%	-3
6	VIII	Hatch #4 + Drilling	52.27%	0
7	IV	Hatch #2 + Drilling	48.83%	-1
8	VI	Hatch #3 + Drilling	44.28%	0

Category	Criteria	Relevance	Grade
Technical	Shielding	Low relevance	6
	Operational time	Relevant	8
	Complexity	Moderate relevance	7
	Flexibility	Moderate relevance	7
	Recoverability of equipment	Very relevant	9
	Emergency response	Very relevant	9
	Robustness	Low relevance	6
	Dedicated solution	Relevant	8
	Size of opening	Moderate relevance	7
	Economic	Investment	Very relevant
Wearing parts		Relevant	8
Lifespan		Moderate relevance	7

Task 3: Optioneering and development of Conceptual Design

NUKEM Technologies Engineering Services (NUKEM)

Fukushima Daiichi NPP Projects: Studies on remotely-operated field work to investigate key aspects and identify major risks of the remotely-operated field work to be realized at Unit 1:

- Cost estimation for intermediate cell of fuel debris sampling;
- Opening on building wall and rough design of remote-controlled shielding door;
- Advanced concept study for intermediate cell of fuel debris sampling;
- Study on installation of a connecting structure with isolating function to X6 port of Unit 1.

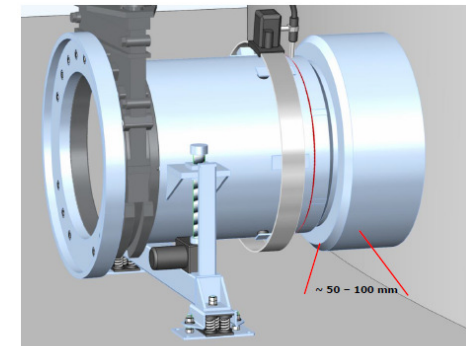

Figure 17: orbital welding of the new pipe to X-6 pipe

To fulfil the client's requirements, NUKEM has provided the following services:

- Use of standard evaluation methods for selection of most suitable technologies;
- Concept design for preferred concept variation;
- 3D modelling of working area covering different scenarios and of specific equipment;
- Recommendation on the most suitable out-of-the-shelf technologies applicable for the concepts together with necessary improvement suggestions.

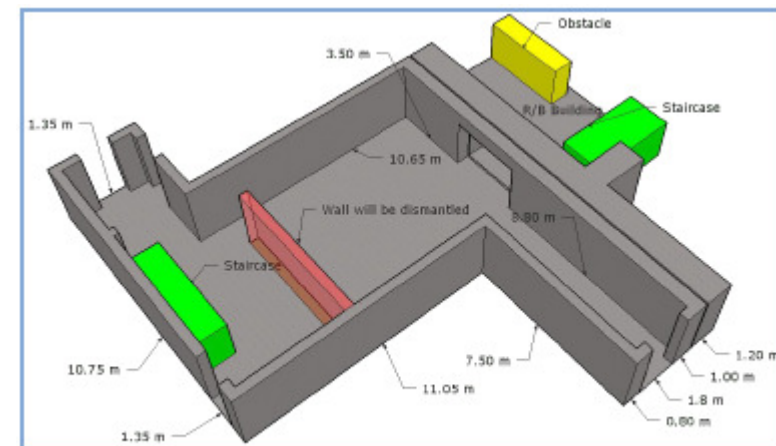
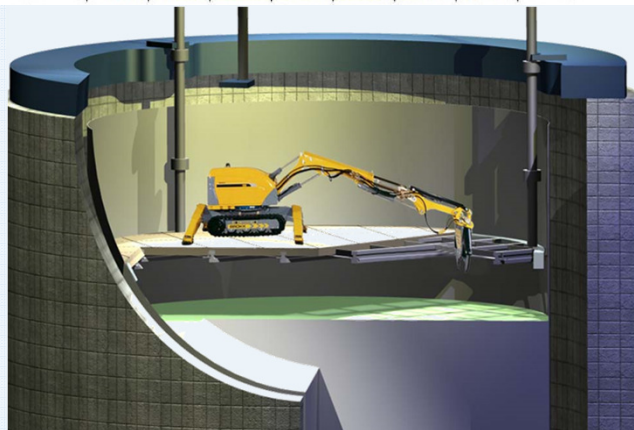
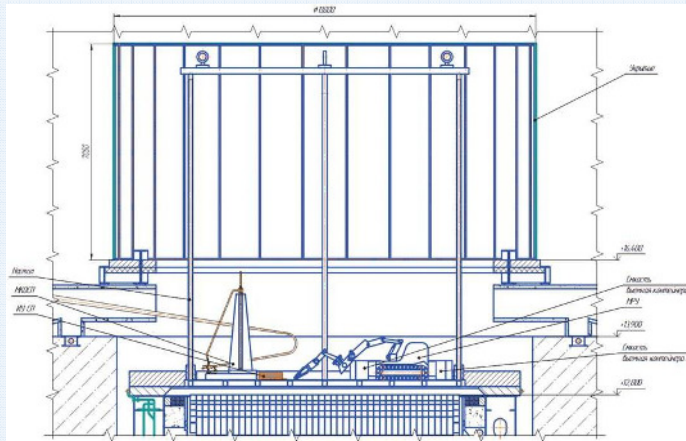

Figure 17: Sketch [1] of the assumed working area according to MHI comments

Optioneering and development of Conceptual Design (1/4)

NIKIET, PDC UGR - Conceptual designs of ADE-5 graphite stack dismantling options

Graphite blocks retrieval in the case of full dismantling of metal structure «scheme E»



Variant of graphite stack dismantling through the hole in metal structure «scheme E»

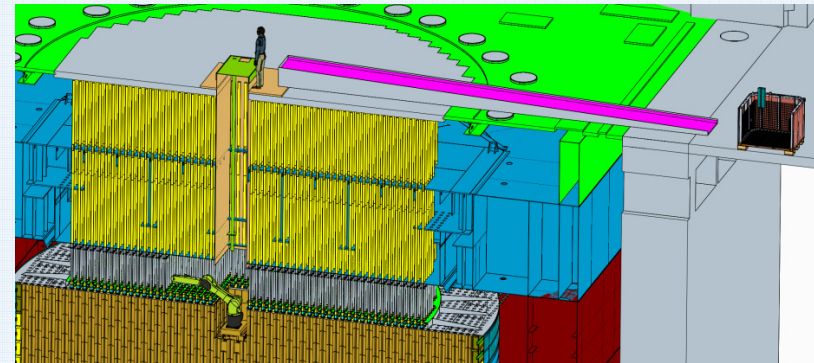

Mockup-simulator for dismantling technologies training (located at the PDC UGR site): Training of manipulator operations and hole preparation operations are being started (at the ADE-5 site)

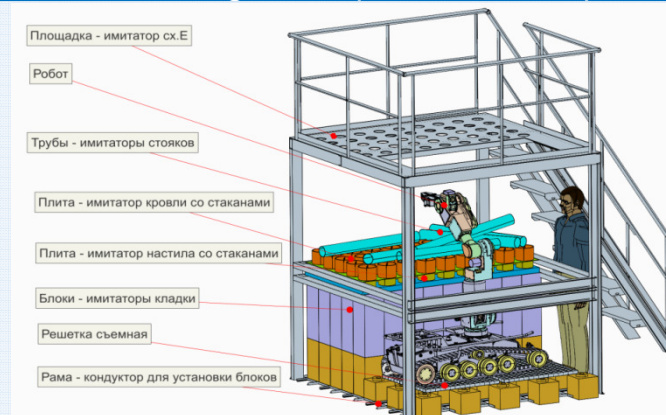

NIKIET has implemented a similar project of optioneering for graphite stack dismantling at ADE-5 reactor – UGR reactor.

Task 3: Optioneering and development of Conceptual Design

NIKIET, PDC UGR - Reference Project on the development of ADE-5 (PDC UGR site) graphite stack dismantling technological operations sequence. As the result of optioneering, the technological operations sequence will be developed and approved.

TECHNOLOGICAL OPERATIONS SEQUENCE

3 MAJOR STAGES

Providing access to the graphite stack

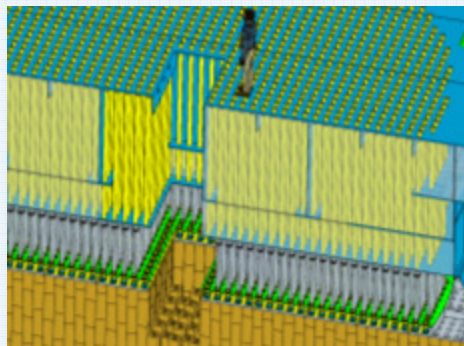

Dismantling and removal of graphite blocks

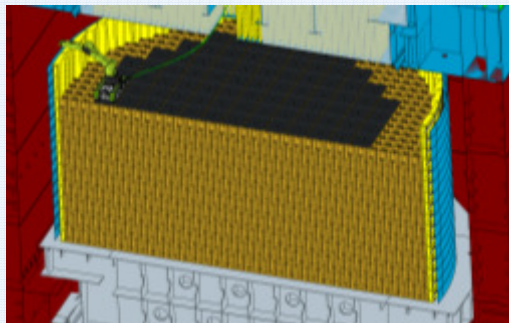

Management of extracted RW

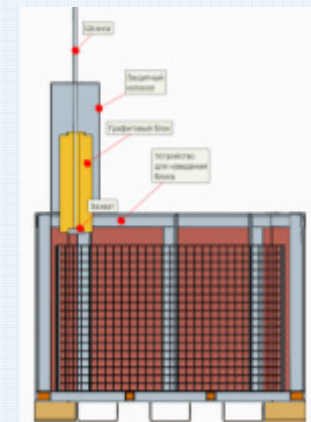

Task 3: Optioneering and development of Conceptual Design

NIKIET, NIKIMT-Atomstroy, Rosenergoatom, Kurchatov Institute and third party Russian tool manufacturers - Reference Project on the design and realisation for extension of RBMK service life time at Len NPP 1 unit (in operation from 1974)

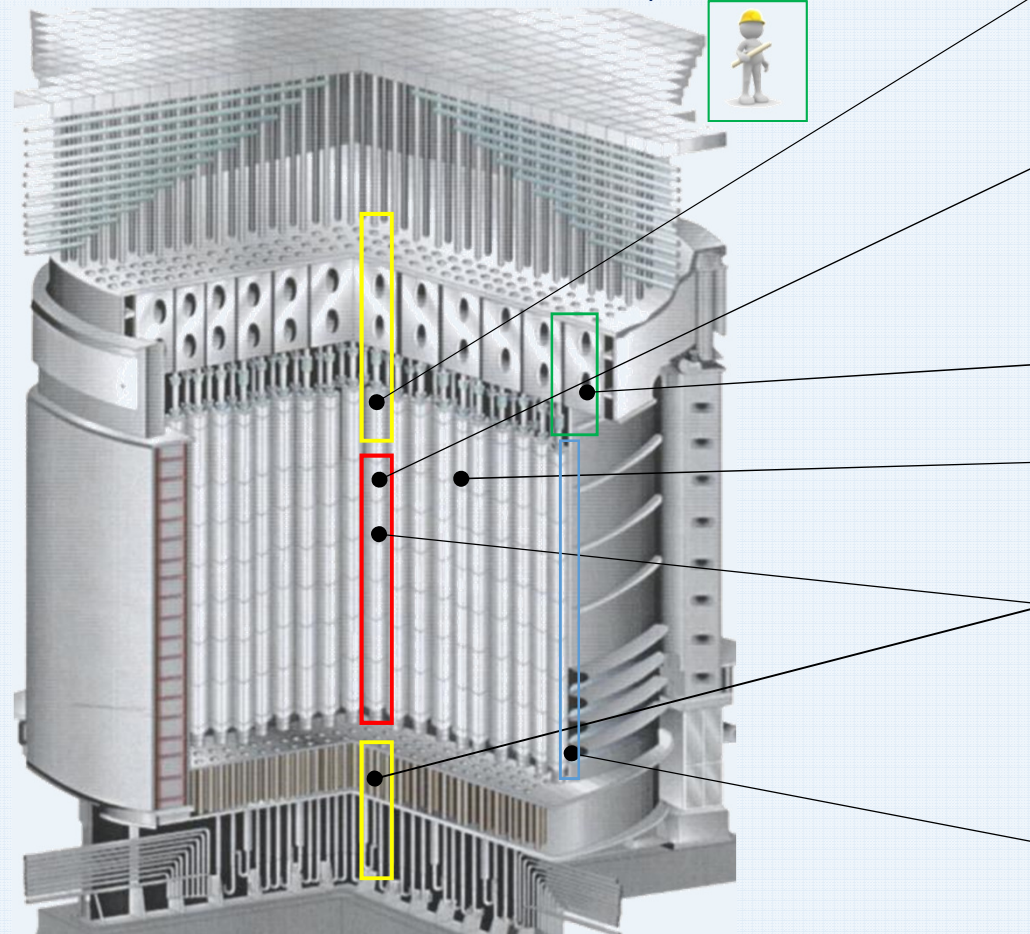

- Reactor core elements control (inside the core space)

- Measuring the deflection boom, azimuth and radius of curvature of technological channels.
- Condition monitoring of graphite columns

- Creation of holes

- Creation of holes inside the core space

- Dismantling of technological channels,
- Cutting and calibration of graphite blocks
- Control of cutting process, graphite elements retrieval

- Graphite blocks cutting and retrieval

Within the implementation of RBMK service life extension, 120 tons of i-graphite was retrieved. We know how to provide safe access to graphite stack.

Task 3: Optioneering and development of Conceptual Design

Kurchatov Institute experience

Remote implementation of CERS



Removal of reactor internals



Reactor area dismantling: research reactors MR and RTF (Moscow).

- Remote implementation of comprehensive engineering and radiation survey (CERS);
- On-site treatment of radwaste by mobile complexes, dust-control, dry decontamination
- Remote cutting of reactor elements;
- Packing RW in protective containers;

Research reactors MR & RTF:

Reactor types: pool type reactor with number of experimental loops (MR), uranium-graphite reactor (RTF)

Operation years: 1962-1992 (1952-1962)

Decommissioning period : ~2008 – 2014. Decommissioned to brownfield

Site rehabilitation – since 2015.



Channels cutting in the reactor pool



Task 3: Optioneering and development of Conceptual Design

The team partner Kurchatov Institute has realized similar work e.g. at its own site during D&D of Research Reactors RFT (UGR) (Conceptual design, Options & Realisation).



Dismantling of reactor head



Graphite stack of reactor RFT



After dismantling of reactor internals



Emptied reactor shaft

I-Graphite management (1)

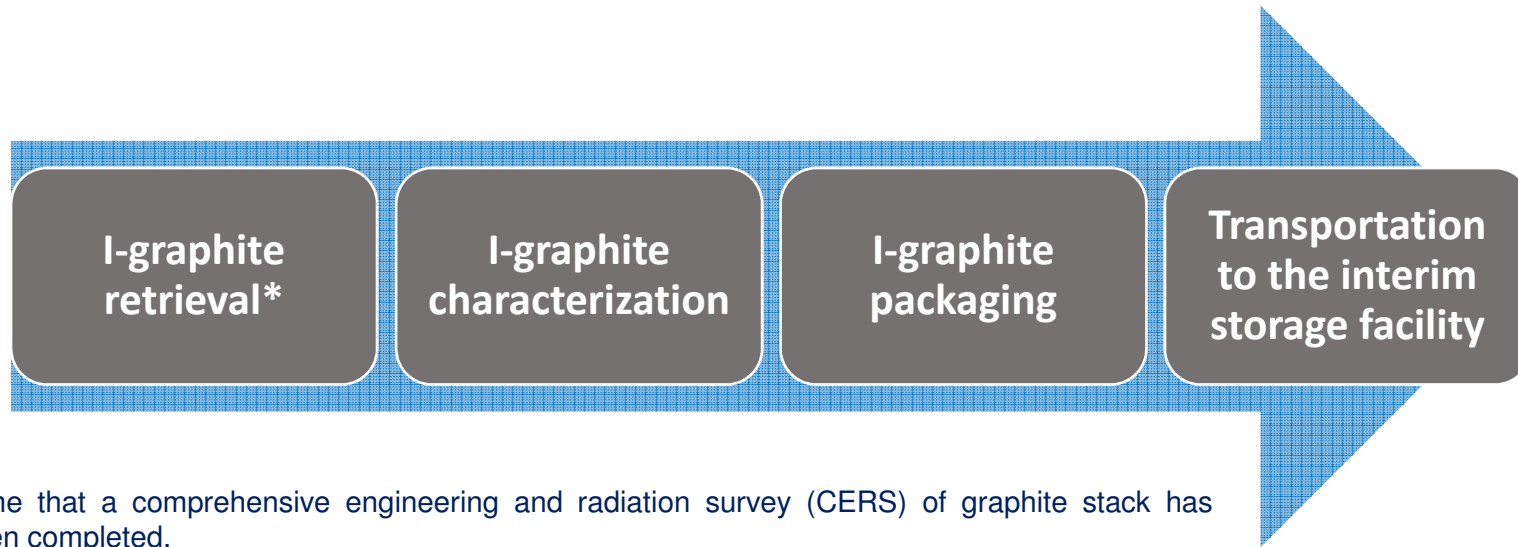

*We assume that a comprehensive engineering and radiation survey (CERS) of graphite stack has already been completed.

At Ignalina NPP or in Lithuania, there is no Deep Geological Disposal Facility available.

Therefore, i-graphite management logic will be based on the following:

- i-graphite retrieval/packaging & safety assessment (without preliminary treatment);
- Transportation to the B4 ILW-LL Storage Facility (under commissioning) or
- Transportation to the Near Surface Repository (design developed, construction under preparation) for interim storage, if that is in compliance with NSR WAC.

Within the frame of this presentation, some alternative i-graphite preliminary treatment options will also be offered.

I-Graphite management (2)

NIKIET, NIKIMT-Atomstroy, Rosenergoatom, Kurchatov Institute and third party Russian tool manufacturers - Application of graphite columns cutting tools, visual-measuring control tools and cutting product collecting systems applied at Len NPP.

Graphite block cutting tool

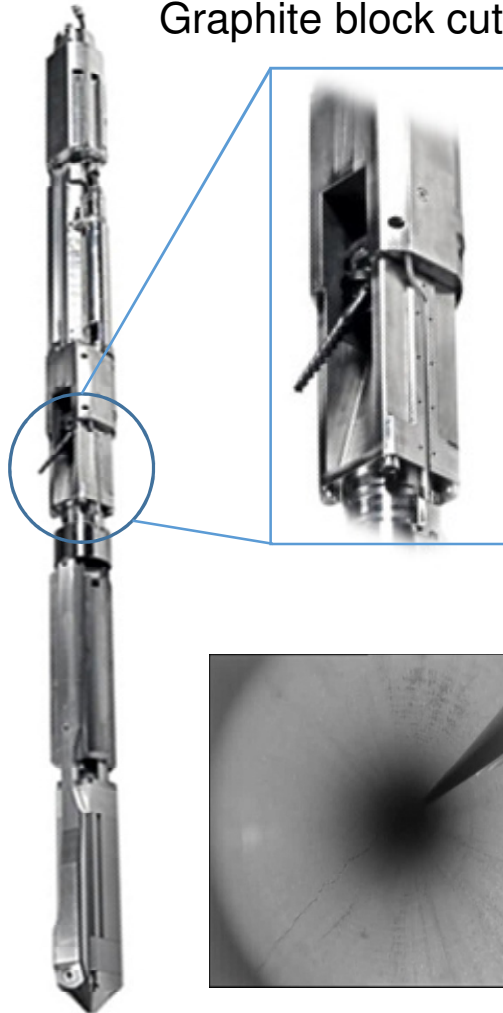

Graphite blocks calibration tool (horizontal cutting)

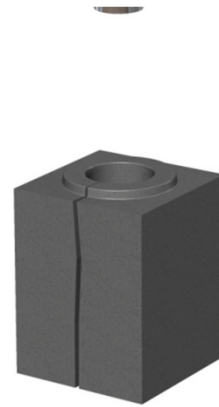

Graphite utilization system

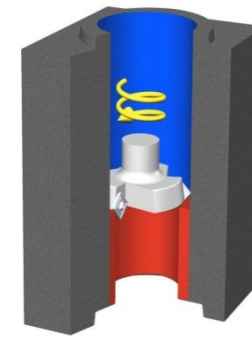
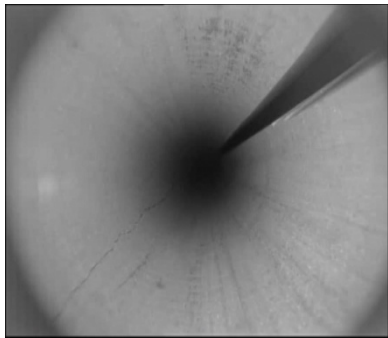

I-Graphite management (3)

NIKIET, PDC UGR, FSUE Radon - Application of graphite columns cutting tools, visual - measuring control tools and cut product collecting systems.

Reactor' graphite retrieval
(PDC UGR site)



Transportation, interim storage
and final disposal

Options of i-graphite disposal

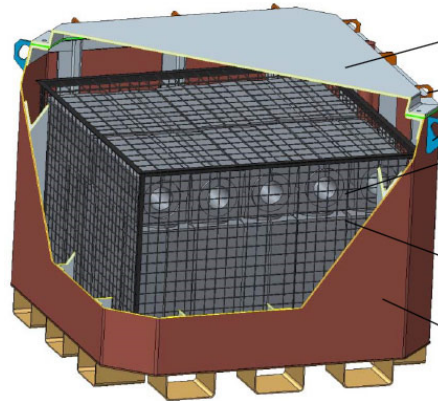

Preliminary treatment option

Treatment (bringing to the waste acceptance criteria for storage and final disposal)

Pilot installation of graphite oxidation in molten salt



Pilot installation of graphite decontamination located at the FSUE RADON site



I-Graphite management – Treatment Solution (1/2)

Preliminary treatment option The solution for managing irradiated graphite Impermeable Graphite Matrix (IGM)

- IGM is a composite material out of Graphite and Glass
- IGM is a special kind of vitrification for irradiated graphite without volume increase.
- Embedding of nuclear waste in IGM is a complementary process to vitrification.
- The main steps of the technology are described below.
- Small test systems was successfully built and tested by German company ALD for a Spanish Customer.

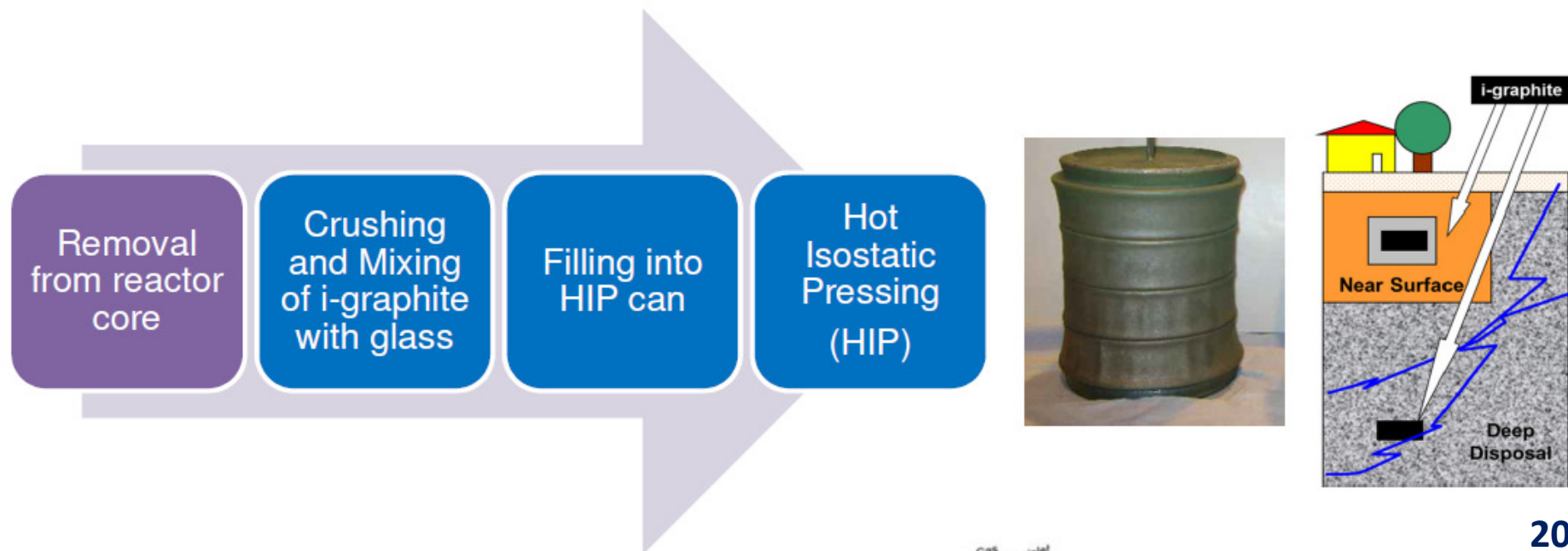

I-Graphite management – Treatment Solution (2/2)

NUKEMs partner ALD: View of an industrial facility



IGM for i-graphite - Manufacturing



Process Line with a HIP

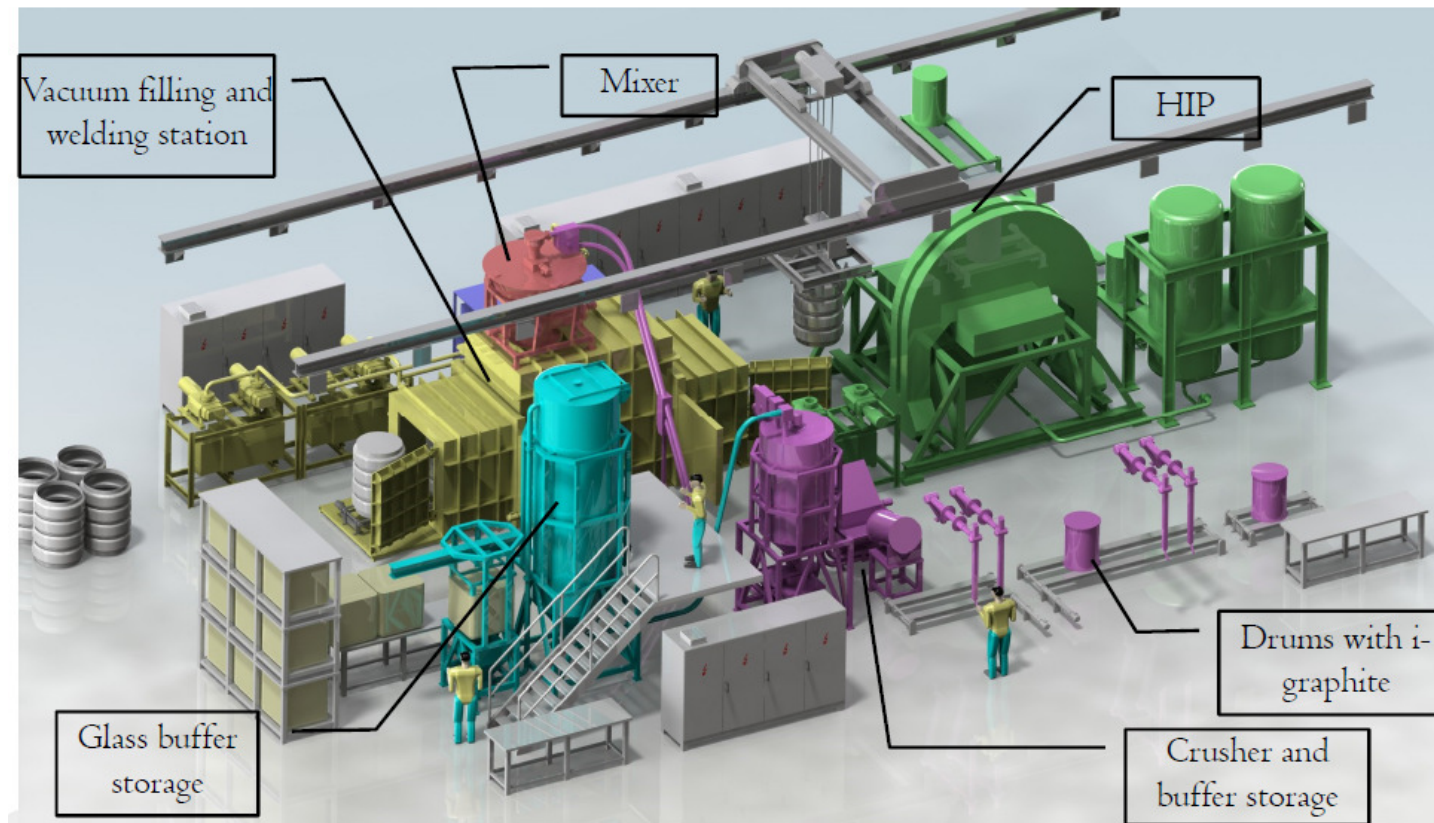

Task 4: Support for INPP during the coordination of Conceptual Design outputs with VATESI, CPMA and Ministry of Energy

The assistance to be provided by the team to INPP during Task 4 will include (as a minimum):

- Provision of advice, both written and oral, in meetings or during round-table discussions,
- Response to, and resolving questions raised on the safety of the conceptual design by VATESI,
- Adaptation of the provided documents to satisfy comments from involved institutions, and
- Additional clarifications and justifications, as well as amending the Task 3 documentation.

The team members that have already intensively participated in the preparation of the documentation will be involved in the INPP support for Task 4.

Task 5: EIAR Development

The team partner NUKEM has provided EIA Report to INPP as part of the Turn-key projects at Ignalina NPP.

The document has to be developed in accordance with the requirements of Lithuanian Norms and Standards.

NUKEM therefore involved a well qualified local company in order to provide the document with the required content and in the Lithuanian language.

It is NUKEM's standard practice to involve local companies for specific tasks, mainly related to licensing issues, in any project abroad.

Task 6: Support for INPP during EIAR approval under Law on environmental impact assessment and Espoo convention

The team is ready to assist INPP in responding to, and resolving, questions raised by institutions of the State and public for approval of the EIAR and, in particular, in the transboundary context of Espoo Convention, (i.e. the general obligation of States to notify and consult each other on all major projects under consideration that are likely to have a significant adverse environmental impact across boundaries).

The assistance to be provided by the team during Task 6 will include (as a minimum):

- Provision of advice, both written and oral, in meetings or during round-table discussions,
- Response to, and resolving, questions raised on the EIA Report by competent authorities and municipal administrations, the public and intergovernmental organisation ESPOO.
- Adaptation of the provided documents to satisfy comments from involved institutions, and
- Additional clarifications and justifications, as well as amending the Task 5 documentation.

The team members that have already intensively participated in the preparation of the documentation will be involved in the INPP support for Task 6.

Similar service provided by all team members during the implementation of RAW management and D&D projects, e.g. the work of the Kurchatov Institute in Northwest Russia (Gremikha, Saida Bay, Andreeva Bay, etc).

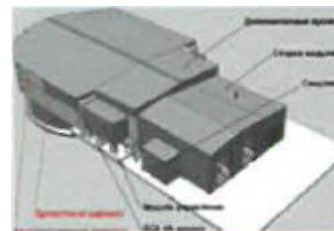

Key project risks

Description of the risk	Response activities
Initial data preparation	We understand that a significant part of operational/manufacturing documents was lost. On the other hand we have a wide range of experimental data on the operation of RBMK in various modes (data on operation of Russian RBMK reactor installations). Due to the fact that our team includes the chief designer of RBMK, we have a full set of RBMK design documentation at our disposal.
Possible change in legislation related to the RW management (boundary conditions and limitations)	Close cooperation with the Lithuanian regulator as well as involvement of Lithuanian organizations (as subcontractors)
Delay the progress of some predecessors projects	Close cooperation with Lithuanian stakeholders
R3D.01 Project is the first-of-kind project regarding the RMBK R3 zone dismantling	Use of past experience in the recovery of resource characteristics of RBMK graphite stacks. Use of past experience in the dismantling of RBMK fuel channels parts.

Conclusions

The provided information of the German – Russian Team confirms the full understanding of the tasks to be fulfilled during the execution of the announced project for the Conceptual D&D Design of R3.

The team partners have extensive own national and international experience in the implementation of similar D&D projects from the very beginning of D&D activities and during different design phases, approval by authorities and provision of D&D services.

The provided reference information confirms the similarity the tasks.

The involvement of the designer of RBMK units, a Russian scientific & design organization and a German D&D design and service provider is a strong basis for the successful completion of this unique project.